



CYDM064B16, CYDM128B16, CYDM256B16

1.8V 4K/8K/16K x 16 and 8K/16K x 8 MoBL[®] Dual-Port Static RAM

Features

- True dual-ported memory cells that allow simultaneous access of the same memory location
- 4, 8, or 16K x 16 organization
- Ultra Low operating power
 - Active: ICC = 15 mA (typical) at 55 ns
 - Standby: I_{SB3} = 2 μA (typical)
- Small footprint: Available in a 6x6 mm 100-pin Pb-free vFBGA
- Port independent 1.8V, 2.5V, and 3.0V IOs
- Full asynchronous operation
- Automatic power down
- Pin select for Master or Slave
- Expandable data bus to 32 bits with Master or Slave chip select when using more than one device
- On-chip arbitration logic
- Semaphores included to permit software handshaking between ports
- Input read registers and output drive registers
- INT flag for port-to-port communication
- Separate upper-byte and lower-byte control
- Industrial temperature ranges

Selection Guide for V_{CC} = 1.8V

Parameter	CYDM256B16, CYDM128B16, CYDM064B16	Unit
	(-55)	
Port IO Voltages (P1-P2)	1.8V -1.8V	V
Maximum Access Time	55	ns
Typical Operating Current	15	mA
Typical Standby Current for I _{SB1}	2	μA
Typical Standby Current for I _{SB3}	2	μA

Selection Guide for V_{CC} = 2.5V

Parameter	CYDM256B16, CYDM128B16, CYDM064B16	Unit
	(-55)	
Port IO Voltages (P1-P2)	2.5V-2.5V	V
Maximum Access Time	55	ns
Typical Operating Current	28	mA
Typical Standby Current for I _{SB1}	6	μA
Typical Standby Current for I _{SB3}	4	μA

Selection Guide for V_{CC} = 3.0V

Parameter	CYDM256B16, CYDM128B16, CYDM064B16	Unit
	(-55)	
Port IO Voltages (P1-P2)	3.0V-3.0V	V
Maximum Access Time	55	ns
Typical Operating Current	42	mA
Typical Standby Current for I _{SB1}	7	μA
Typical Standby Current for I _{SB3}	6	μA

Logic Block Diagram [1, 2]

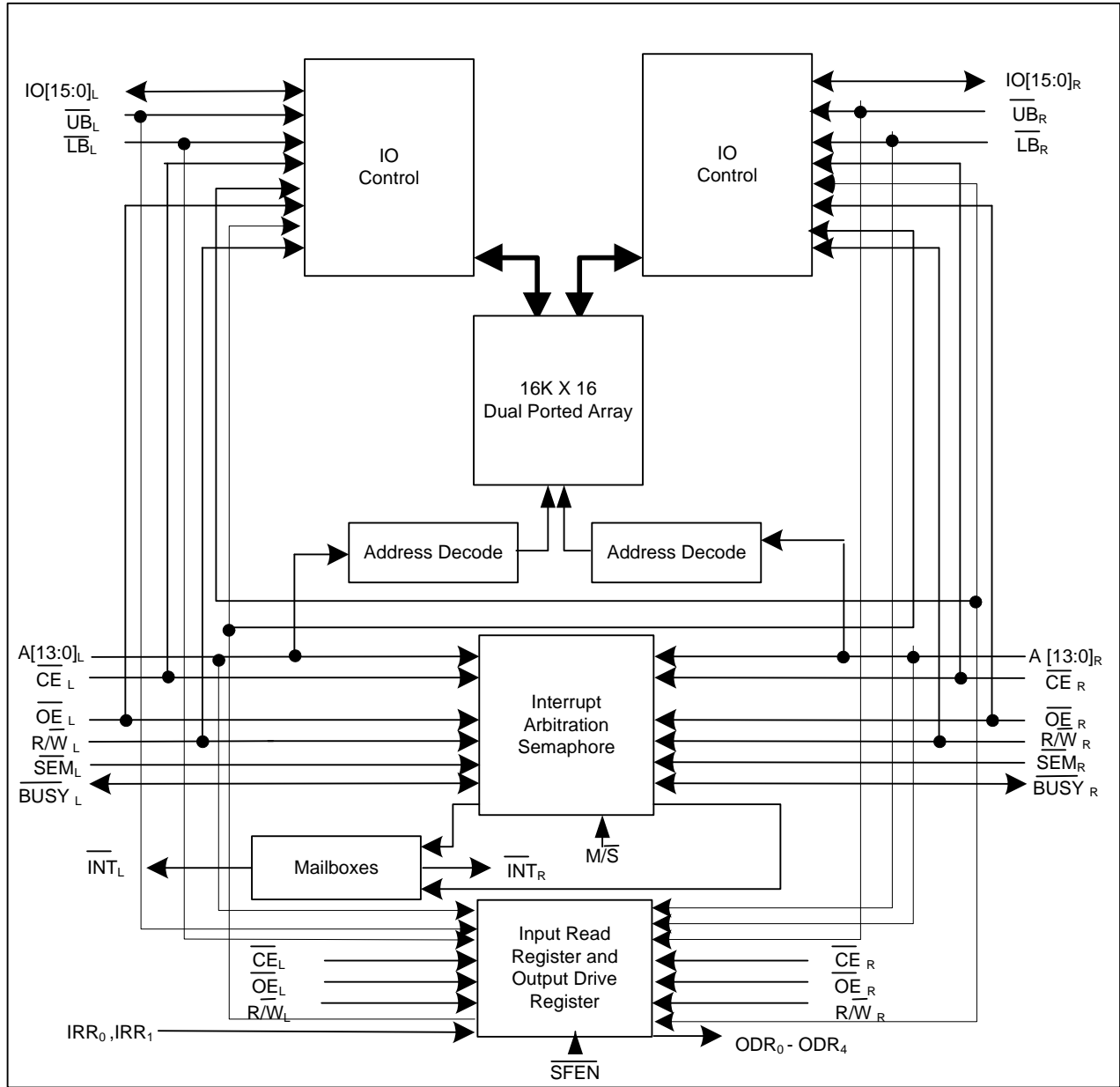

Notes

1. A₀-A₁₁ for 4K devices; A₀-A₁₂ for 8K devices; A₀-A₁₃ for 16K devices.
2. BUSY is an output in master mode and an input in slave mode.

Pinouts

Figure 1. Ball Diagram - 100-Ball 0.5 mm Pitch BGA (Top View) ^[3, 4, 5, 6, 7]

CYDM064B16, CYDM128B16, CYDM256B16

	1	2	3	4	5	6	7	8	9	10	
A	A _{5R}	A _{8R}	A _{11R}	UB _R	V _{SS}	SEM _R	IO _{15R}	IO _{12R}	IO _{10R}	V _{SS}	A
B	A _{3R}	A _{4R}	A _{7R}	A _{9R}	CE _R	R/W _R	OE _R	V _{DDIOR}	IO _{9R}	IO _{6R}	B
C	A _{0R}	A _{1R}	A _{2R}	A _{6R}	LB _R	IRR1 ^[6]	IO _{14R}	IO _{11R}	IO _{7R}	V _{SS}	C
D	ODR4	ODR2	BUSY _R	INT _R	A _{10R}	A _{12R} ^[3]	IO _{13R}	IO _{8R}	IO _{5R}	IO _{2R}	D
E	V _{SS}	M/S	ODR3	INT _L	V _{SS}	V _{SS}	IO _{4R}	V _{DDIOR}	IO _{1R}	V _{SS}	E
F	SFEN	ODR1	BUSY _L	A _{1L}	V _{CC}	V _{SS}	IO _{3R}	IO _{0R}	IO _{15L}	V _{DDIOL}	F
G	ODR0	A _{2L}	A _{5L}	A _{12L} ^[3]	OE _L	IO _{3L}	IO _{11L}	IO _{12L}	IO _{14L}	IO _{13L}	G
H	A _{0L}	A _{4L}	A _{9L}	LB _L	CE _L	IO _{1L}	V _{DDIOL}	NC ^[7]	NC ^[7]	IO _{10L}	H
J	A _{3L}	A _{7L}	A _{10L}	IRR0 ^[5]	V _{CC}	V _{SS}	IO _{4L}	IO _{6L}	IO _{8L}	IO _{9L}	J
K	A _{6L}	A _{8L}	A _{11L}	UB _L	SEM _L	R/W _L	IO _{0L}	IO _{2L}	IO _{5L}	IO _{7L}	K
	1	2	3	4	5	6	7	8	9	10	

Notes

3. A12L and A12R are NC pins for CYDM064B16.
4. IRR functionality is not supported for the CYDM256B16 device.
5. This pin is A13L for CYDM256B16 device.
6. This pin is A13R for CYDM256B16 device.
7. Leave this pin unconnected. No trace or power component can be connected to this pin.

Table 1. Pin Definitions - 100-Ball 0.5 mm Pitch BGA (CYDM064B16, CYDM128B16, CYDM256B16)

Left Port	Right Port	Description
\overline{CE}_L	\overline{CE}_R	Chip Enable
R/\overline{W}_L	R/\overline{W}_R	Read or Write Enable
\overline{OE}_L	\overline{OE}_R	Output Enable
$A_{0L}-A_{13L}$	$A_{0R}-A_{13R}$	Address (A_0-A_{11} for 4K devices; A_0-A_{12} for 8K devices; A_0-A_{13} for 16K devices)
$IO_{0L}-IO_{15L}$	$IO_{0R}-IO_{15R}$	Data Bus Input or Output for x16 devices
\overline{SEM}_L	\overline{SEM}_R	Semaphore Enable
\overline{UB}_L	\overline{UB}_R	Upper Byte Select (IO_8-IO_{15})
\overline{LB}_L	\overline{LB}_R	Lower Byte Select (IO_0-IO_7)
\overline{INT}_L	\overline{INT}_R	Interrupt Flag
\overline{BUSY}_L	\overline{BUSY}_R	Busy Flag
IRR0, IRR1		Input Read Register for CYDM064B16 and CYDM128B16 A13L and A13R for CYDM256B16.
ODR0-ODR4		Output Drive Register. These outputs are Open Drain.
\overline{SFEN}		Special Function Enable
M/\overline{S}		Master or Slave Select
V_{CC}		Core Power
GND		Ground
V_{DDIOL}		Left Port IO Voltage
V_{DDIOR}		Right Port IO Voltage
NC		No Connect. Leave this pin Unconnected.

Functional Description

The CYDM256B16, CYDM128B16, and CYDM064B16 are low power CMOS 4K, 8K, 16K x 16 dual-port static RAMs. Arbitration schemes are included on the devices to handle situations when multiple processors access the same piece of data. Two ports are provided that permit independent, asynchronous access for reads and writes to any location in memory. The devices can be used as standalone 16-bit dual-port static RAMs or multiple devices can be combined to function as a 32-bit or wider master/slave dual-port static RAM. An M/S pin is provided for implementing 32-bit or wider memory applications without the need for separate master and slave devices or additional discrete logic. Application areas include interprocessor or multi-processor designs, communications status buffering, and dual-port video or graphics memory.

Each port has independent control pins: Chip Enable (\overline{CE}), Read or Write Enable (R/W), and Output Enable (\overline{OE}). Two flags are provided on each port (BUSY and INT). BUSY indicates that the port is trying to access the same location currently being accessed by the other port. The Interrupt flag (\overline{INT}) permits communication between ports or systems through a mail box. The semaphores are used to pass a flag or token, from one port to the other, to indicate that a shared resource is in use. The semaphore logic consists of eight shared latches. Only one side can control the latch (semaphore) at any time. Control of a semaphore indicates that a shared resource is in use. An automatic power down feature is controlled independently on each port by a Chip Enable (\overline{CE}) pin.

The CYDM256B16, CYDM128B16, CYDM064B16 are available in 100-ball 0.5 mm pitch Ball Grid Array (BGA) packages.

Power Supply

The core voltage (V_{CC}) can be 1.8V, 2.5V, or 3.0V, as long as it is lower than or equal to the IO voltage.

Each port can operate on independent IO voltages. This is determined by what is connected to the V_{DDIOL} and V_{DDIOR} pins. The supported IO standards are 1.8V or 2.5V LVCMOS and 3.0V LVTTTL.

Write Operation

Data must be set up for a duration of t_{SD} before the rising edge of R/W to guarantee a valid write. A write operation is controlled by either the R/W pin (see Figure 5 on page 18) or the \overline{CE} pin (see Figure 6 on page 18). Required inputs for noncontention operations are summarized in Table 2 on page 7.

If a location is being written to by one port and the opposite port attempts to read that location, a port-to-port flowthrough delay must occur before the data is read on the output. Otherwise, the data read is not deterministic. Data is valid on the port t_{DD} after the data is presented on the other port.

Read Operation

When reading the device, the user must assert both the \overline{OE} and \overline{CE} pins. Data is available t_{ACE} after \overline{CE} or t_{DOE} after \overline{OE} is asserted. If the user wishes to access a semaphore flag, then the \overline{SEM} pin must be asserted instead of the \overline{CE} pin, and \overline{OE} must also be asserted.

Interrupts

The upper two memory locations may be used for message passing. The highest memory location (FFF for the CYDM064B16, 1FFF for the CYDM128B16, 3FFF for the CYDM256B16) is the mailbox for the right port and the second-highest memory location (FFE for the CYDM064B16, 1FFE for the CYDM128B16, 3FFE for the CYDM256B16) is the mailbox for the left port. When one port writes to the other port's mailbox, an interrupt is generated to the owner. The interrupt is reset when the owner reads the contents of the mailbox. The message is user-defined.

Each port can read the other port's mailbox without resetting the interrupt. The active state of the busy signal (to a port) prevents the port from setting the interrupt to the winning port. Also, an active busy to a port prevents that port from reading its own mailbox and, thus, resetting the interrupt to it.

If an application does not require message passing, do not connect the interrupt pin to the processor's interrupt request input pin. On power up, an initialization program must be run and the interrupts for both ports must be read to reset them.

The operation of the interrupts and their interaction with Busy are summarized in Table 3 on page 7.

Busy

The CYDM256B16, CYDM128B16, and CYDM064B16 provide on-chip arbitration to resolve simultaneous memory location access (contention). If both port \overline{CE} s are asserted and an address match occurs within t_{PS} of each other, the busy logic determines which port has access. If t_{PS} is violated, one port definitely gains permission to the location. However, which port gets this permission cannot be predicted. BUSY is asserted t_{BLA} after an address match or t_{BLC} after \overline{CE} is taken LOW.

Master/Slave

An M/S pin is provided to expand the word width by configuring the device as either a master or a slave. The BUSY output of the master is connected to the \overline{BUSY} input of the slave. This allows the device to interface to a master device with no external components. Writing to slave devices must be delayed until after the \overline{BUSY} input has settled (t_{BLC} or t_{BLA}). Otherwise, the slave chip may begin a write cycle during a contention situation. When tied HIGH, the M/S pin allows the device to be used as a master and, as a result, the BUSY line is an output. BUSY can then be used to send the arbitration outcome to a slave.

Input Read Register

The Input Read Register (IRR) captures the status of two external input devices that are connected to the Input Read pins.

The contents of the IRR read from address x0000 from either port. During reads from the IRR, DQ0 and DQ1 are valid bits and DQ<15:2> are don't care. Writes to address x0000 are not allowed from either port.

Address x0000 is not available for standard memory accesses when SFEN = V_{IL}. When SFEN = V_{IH}, address x0000 is available for memory accesses.

The inputs are 1.8V/2.5V LVCMOS or 3.0V LVTTTL, depending on the core voltage supply (V_{CC}). Refer to Table 4 on page 8 for Input Read Register operation.

IRR is not available in the CYDM256B16, because the IRR pins are used as extra address pins A_{13L} and A_{13R}.

Output Drive Register

The Output Drive Register (ODR) determines the state of up to five external binary state devices by providing a path to V_{SS} for the external circuit. These outputs are Open Drain.

The five external devices can operate at different voltages (1.5V ≤ V_{DDIO} ≤ 3.5V) but the combined current cannot exceed 40 mA (8 mA max for each external device). The status of the ODR bits are set using standard write accesses from either port to address x0001 with a "1" corresponding to on and "0" corresponding to off.

The status of the ODR bits can be read with a standard read access to address x0001. When SFEN = V_{IL}, the ODR is active and address x0001 is not available for memory accesses. When SFEN = V_{IH}, the ODR is inactive and address x0001 can be used for standard accesses.

During reads and writes to ODR DQ<4:0> are valid and DQ<15:5> are don't care. Refer to Table 5 on page 8 for Output Drive Register operation.

Semaphore Operation

The CYDM256B16, CYDM128B16, and CYDM064B16 provide eight semaphore latches, which are separate from the dual-port memory locations. Semaphores are used to reserve resources that are shared between the two ports. The state of the semaphore indicates that a resource is in use. For example, if the left port wants to request a given resource, it sets a latch by writing a zero to a semaphore location. The left port then verifies its success in setting the latch by reading it. After writing to the semaphore, SEM or OE must be deasserted for t_{SOP} before attempting to read the semaphore. The semaphore value is available t_{SWRD} + t_{DOE} after the rising edge of the semaphore write. If the left port is successful (reads a zero), it assumes control of the shared resource. Otherwise (reads a one), it assumes the right port has control and continues to poll the semaphore. When the right side has relinquished control of the semaphore (by writing a one), the left side succeeds in gaining control of the semaphore. If the left side no longer requires the semaphore, a one is written to cancel its request.

Semaphores are accessed by asserting SEM LOW. The SEM pin functions as a chip select for the semaphore latches (CE must remain HIGH during SEM LOW). A₀₋₂ represents the semaphore address. OE and R/W are used in the same manner as a normal memory access. When writing or reading a semaphore, the other address pins have no effect.

When writing to the semaphore, only IO₀ is used. If a zero is written to the left port of an available semaphore, a one appears at the same semaphore address on the right port. That semaphore can now only be modified by the side showing zero (the left port in this case). If the left port now relinquishes control by writing a one to the semaphore, the semaphore is set to one for both sides. However, if the right port requests the semaphore (written a zero) while the left port has control, the right port immediately owns the semaphore as soon as the left port releases it. Table 6 on page 8 shows sample semaphore operations.

When reading a semaphore, all sixteen data lines output the semaphore value. The read value is latched in an output register to prevent the semaphore from changing state during a write from the other port. If both ports attempt to access the semaphore within t_{SPS} of each other, the semaphore is definitely obtained by one side or the other, but there is no guarantee which side controls the semaphore. On power up, both ports must write "1" to all eight semaphores.

Architecture

The CYDM256B16, CYDM128B16, and CYDM064B16 consist of an array of 4K, 8K, or 16K words of 16 dual-port RAM cells, IO and address lines, and control signals (CE, OE, R/W). These control pins permit independent access for reads or writes to any location in memory. To handle simultaneous writes or reads to the same location, a BUSY pin is provided on each port. Two Interrupt (INT) pins can be used for port-to-port communication. Two Semaphore (SEM) control pins are used to allocate shared resources. With the M/S pin, the devices can function as a master (BUSY pins are outputs) or as a slave (BUSY pins are inputs). The devices also have an automatic power down feature controlled by CE. Each port is provided with its own output enable control (OE), which allows data to be read from the device.

Table 2. NonContending Read/Write



Inputs						Outputs		Operation
\overline{CE}	$\overline{R/W}$	\overline{OE}	\overline{UB}	\overline{LB}	\overline{SEM}	IO_8-IO_{15}	IO_0-IO_7	
H	X	X	X	X	H	High Z	High Z	Deselected: Power down
X	X	X	H	H	H	High Z	High Z	Deselected: Power down
L	L	X	L	H	H	Data In	High Z	Write to Upper Byte Only
L	L	X	H	L	H	High Z	Data In	Write to Lower Byte Only
L	L	X	L	L	H	Data In	Data In	Write to Both Bytes
L	H	L	L	H	H	Data Out	High Z	Read Upper Byte Only
L	H	L	H	L	H	High Z	Data Out	Read Lower Byte Only
L	H	L	L	L	H	Data Out	Data Out	Read Both Bytes
X	X	H	X	X	X	High Z	High Z	Outputs Disabled
H	H	L	X	X	L	Data Out	Data Out	Read Data in Semaphore Flag
X	H	L	H	H	L	Data Out	Data Out	Read Data in Semaphore Flag
H		X	X	X	L	Data In	Data In	Write D_{IN0} into Semaphore Flag
X		X	H	H	L	Data In	Data In	Write D_{IN0} into Semaphore Flag
L	X	X	L	X	L			Not Allowed
L	X	X	X	L	L			Not Allowed

Table 3. Interrupt Operation Example (Assumes $\overline{BUSY}_L = \overline{BUSY}_R = \text{HIGH}$)^[8]

Function	Left Port					Right Port				
	$\overline{R/W}_L$	\overline{CE}_L	\overline{OE}_L	A_{0L-13L}	\overline{INT}_L	$\overline{R/W}_R$	\overline{CE}_R	\overline{OE}_R	A_{0R-13R}	\overline{INT}_R
Set Right \overline{INT}_R Flag	L	L	X	3FFF ^[11]	X	X	X	X	X	$L^{[10]}$
Reset Right \overline{INT}_R Flag	X	X	X	X	X	X	L	L	3FFF ^[11]	$H^{[9]}$
Set Left \overline{INT}_L Flag	X	X	X	X	$L^{[9]}$	L	L	X	3FFE ^[11]	X
Reset Left \overline{INT}_L Flag	X	L	L	3FFE ^[11]	$H^{[10]}$	X	X	X	X	X

Notes

- 8. See Interrupts Functional Description for specific highest memory locations by device.
- 9. If $\overline{BUSY}_R = L$, then no change.
- 10. If $\overline{BUSY}_L = L$, then no change.
- 11. See section [Functional Description](#) on page 5 for specific addresses by device.

Table 4. Input Read Register Operation^[12, 15]

SFEN	CE	R/W	OE	UB	LB	ADDR	IO ₀ -IO ₁	IO ₂ -IO ₁₅	Mode
H	L	H	L	L	L	x0000-Max	VALID ^[13]	VALID ^[13]	Standard Memory Access
L	L	H	L	X	L	x0000	VALID ^[14]	X	IRR Read

Table 5. Output Drive Register^[16]

SFEN	CE	R/W	OE	UB	LB	ADDR	IO ₀ -IO ₄	IO ₅ -IO ₁₅	Mode
H	L	H	X ^[17]	L ^[13]	L ^[13]	x0000-Max	VALID ^[13]	VALID ^[13]	Standard Memory Access
L	L	L	X	X	L	x0001	VALID ^[14]	X	ODR Write ^[16, 18]
L	L	H	L	X	L	x0001	VALID ^[14]	X	ODR Read ^[16]

Table 6. Semaphore Operation Example

Function	IO ₀ -IO ₁₅ Left	IO ₀ -IO ₁₅ Right	Status
No action	1	1	Semaphore free
Left port writes 0 to semaphore	0	1	Left Port has semaphore token
Right port writes 0 to semaphore	0	1	No change. Right side has no write access to semaphore.
Left port writes 1 to semaphore	1	0	Right port obtains semaphore token
Left port writes 0 to semaphore	1	0	No change. Left port has no write access to semaphore.
Right port writes 1 to semaphore	0	1	Left port obtains semaphore token
Left port writes 1 to semaphore	1	1	Semaphore free
Right port writes 0 to semaphore	1	0	Right port has semaphore token
Right port writes 1 to semaphore	1	1	Semaphore free
Left port writes 0 to semaphore	0	1	Left port has semaphore token
Left port writes 1 to semaphore	1	1	Semaphore free

Notes

12. SFEN = V_{IL} for IRR reads
13. UB or LB = V_{IL}. If LB = V_{IL}, then DQ<7:0> are valid. If UB = V_{IL} then DQ<15:8> are valid.
14. LB must be active (LB = V_{IL}) for these bits to be valid.
15. SFEN active when either CE_L = V_{IL} or CE_R = V_{IL}. It is inactive when CE_L = CE_R = V_{IH}.
16. SFEN = V_{IL} for ODR reads and writes.
17. Output enable must be low (OE = V_{IL}) during reads for valid data to be output.
18. During ODR writes data are also written to the memory.

Maximum Ratings

Exceeding maximum ratings^[19] may shorten the useful life of the device. User guidelines are not tested.

Storage Temperature -65°C to +150°C
 Ambient Temperature with Power Applied..... -55°C to +125°C
 Supply Voltage to Ground Potential -0.5V to +3.3V
 DC Voltage Applied to Outputs in High-Z State..... -0.5V to $V_{CC} + 0.5V$
 DC Input Voltage^[20] -0.5V to $V_{CC} + 0.5V$
 Output Current into Outputs (LOW) 90 mA

Static Discharge Voltage > 2000V
 Latch-up Current > 200 mA

Operating Range

Range	Ambient Temperature	V_{CC}
Commercial	0°C to +70°C	1.8V ± 100 mV 2.5V ± 100 mV 3.0V ± 300 mV
Industrial	-40°C to +85°C	1.8V ± 100 mV 2.5V ± 100 mV 3.0V ± 300 mV

Electrical Characteristics for $V_{CC} = 1.8V$

Over the Operating Range

Parameter	Description	CYDM256B16, CYDM128B16, CYDM064B16					Unit
		-55					
		P1 IO Voltage	P2 IO Voltage	Min	Typ.	Max	
V_{OH}	Output HIGH Voltage ($I_{OH} = -100 \mu A$)	1.8V (any port)		$V_{DDIO} - 0.2$			V
	Output HIGH Voltage ($I_{OH} = -2 \text{ mA}$)	2.5V (any port)		2.0			V
	Output HIGH Voltage ($I_{OH} = -2 \text{ mA}$)	3.0V (any port)		2.1			V
V_{OL}	Output LOW Voltage ($I_{OL} = 100 \mu A$)	1.8V (any port)				0.2	V
	Output HIGH Voltage ($I_{OL} = 2 \text{ mA}$)	2.5V (any port)				0.4	V
	Output HIGH Voltage ($I_{OL} = 2 \text{ mA}$)	3.0V (any port)				0.4	V
$V_{OL \text{ ODR}}$	ODR Output LOW Voltage ($I_{OL} = 8 \text{ mA}$)	1.8V (any port)				0.2	V
		2.5V (any port)				0.2	V
		3.0V (any port)				0.2	V
V_{IH}	Input HIGH Voltage	1.8V (any port)		1.2		$V_{DDIO} + 0.2$	V
		2.5V (any port)		1.7		$V_{DDIO} + 0.3$	V
		3.0V (any port)		2.0		$V_{DDIO} + 0.2$	V
V_{IL}	Input LOW Voltage	1.8V (any port)		-0.2		0.4	V
		2.5V (any port)		-0.3		0.6	V
		3.0V (any port)		-0.2		0.7	V
I_{OZ}	Output Leakage Current	1.8V	1.8V	-1		1	μA
		2.5V	2.5V	-1		1	μA
		3.0V	3.0V	-1		1	μA
$I_{CEX \text{ ODR}}$	ODR Output Leakage Current. $V_{OUT} = V_{DDIO}$	1.8V	1.8V	-1		1	μA
		2.5V	2.5V	-1		1	μA
		3.0V	3.0V	-1		1	μA
I_{IX}	Input Leakage Current	1.8V	1.8V	-1		1	μA
		2.5V	2.5V	-1		1	μA
		3.0V	3.0V	-1		1	μA

Notes

19. The voltage on any input or IO pin can not exceed the power pin during power up.
 20. Pulse width < 20 ns.

Electrical Characteristics for $V_{CC} = 1.8V$ (continued)

Over the Operating Range

Parameter	Description		CYDM256B16, CYDM128B16, CYDM064B16					Unit
			-55					
			P1 IO Voltage	P2 IO Voltage	Min	Typ.	Max	
I_{CC}	Operating Current ($V_{CC} = \text{Max.}$, $I_{OUT} = 0 \text{ mA}$) Outputs Disabled	Ind.	1.8V	1.8V		15	25	mA
I_{SB1}	Standby Current (Both Ports TTL Level) \overline{CE}_L and $\overline{CE}_R \geq V_{CC} - 0.2$, $SEM_L = SEM_R = V_{CC} - 0.2$, $f = f_{MAX}$	Ind.	1.8V	1.8V		2	6	μA
I_{SB2}	Standby Current (One Port TTL Level) \overline{CE}_L $\overline{CE}_R \geq V_{IH}$, $f = f_{MAX}$	Ind.	1.8V	1.8V		8.5	14	mA
I_{SB3}	Standby Current (Both Ports CMOS Level) \overline{CE}_L and $\overline{CE}_R \geq V_{CC} - 0.2V$, SEM_L and $SEM_R > V_{CC} - 0.2V$, $f = 0$	Ind.	1.8V	1.8V		2	6	μA
I_{SB4}	Standby Current (One Port CMOS Level) \overline{CE}_L $\overline{CE}_R \geq V_{IH}$, $f = f_{MAX}$ ^[21]	Ind.	1.8V	1.8V		8.5	14	mA

Electrical Characteristics for $V_{CC} = 2.5V$

Over the Operating Range

Parameter	Description		CYDM256B16, CYDM128B16, CYDM064B16					Unit
			-55					
			P1 IO Voltage	P2 IO Voltage	Min	Typ.	Max	
V_{OH}	Output HIGH Voltage ($I_{OH} = -2 \text{ mA}$)		2.5V (any port)		2.0			V
			3.0V (any port)		2.1			V
V_{OL}	Output LOW Voltage ($I_{OL} = 2 \text{ mA}$)		2.5V (any port)				0.4	V
			3.0V (any port)				0.4	V
$V_{OL} \text{ ODR}$	ODR Output LOW Voltage ($I_{OL} = 8 \text{ mA}$)		2.5V (any port)				0.2	V
			3.0V (any port)				0.2	V
V_{IH}	Input HIGH Voltage		2.5V (any port)		1.7		$V_{DDIO} + 0.3$	V
			3.0V (any port)		2.0		$V_{DDIO} + 0.2$	V
V_{IL}	Input LOW Voltage		2.5V (any port)		-0.3		0.6	V
			3.0V (any port)		-0.2		0.7	V
I_{OZ}	Output Leakage Current		2.5V	2.5V	-1		1	μA
			3.0V	3.0V	-1		1	μA
$I_{CEX} \text{ ODR}$	ODR Output Leakage Current. $V_{OUT} = V_{CC}$		2.5V	2.5V	-1		1	μA
			3.0V	3.0V	-1		1	μA
I_{IX}	Input Leakage Current		2.5V	2.5V	-1		1	μA
			3.0V	3.0V	-1		1	μA
I_{CC}	Operating Current ($V_{CC} = \text{Max.}$, $I_{OUT} = 0 \text{ mA}$) Outputs Disabled	Ind.	2.5V	2.5V		28	40	mA

Notes

 21. $f_{MAX} = 1/t_{RC} = \text{All inputs cycling at } f = 1/t_{RC}$ (except output enable). $f = 0$ means no address or control lines change. This applies only to inputs at CMOS level standby I_{SB3} .

Electrical Characteristics for $V_{CC} = 2.5V$ (continued)

Over the Operating Range

Parameter	Description		CYDM256B16, CYDM128B16, CYDM064B16					Unit
			-55					
			P1 IO Voltage	P2 IO Voltage	Min	Typ.	Max	
I_{SB1}	Standby Current (Both Ports TTL Level) \overline{CE}_L and $\overline{CE}_R \geq V_{CC} - 0.2$, $SEM_L = SEM_R = V_{CC} - 0.2$, $f = f_{MAX}$	Ind.	2.5V	2.5V		6	8	μA
I_{SB2}	Standby Current (One Port TTL Level) \overline{CE}_L $\overline{CE}_R \geq V_{IH}$, $f = f_{MAX}$	Ind.	2.5V	2.5V		18	25	mA
I_{SB3}	Standby Current (Both Ports CMOS Level) \overline{CE}_L and $\overline{CE}_R \geq V_{CC} - 0.2V$, SEM_L and $SEM_R > V_{CC} - 0.2V$, $f = 0$	Ind.	2.5V	2.5V		4	6	μA
I_{SB4}	Standby Current (One Port CMOS Level) \overline{CE}_L $\overline{CE}_R \geq V_{IH}$, $f = f_{MAX}^{[21]}$	Ind.	2.5V	2.5V		18	25	mA

Electrical Characteristics for 3.0V Over the Operating Range

Parameter	Description		CYDM256B16, CYDM128B16, CYDM064B16					Unit
			-55					
			P1 IO Voltage	P2 IO Voltage	Min	Typ.	Max	
V_{OH}	Output HIGH Voltage ($I_{OH} = -2$ mA)		3.0V (any port)		2.1			V
V_{OL}	Output LOW Voltage ($I_{OL} = 2$ mA)		3.0V (any port)				0.4	V
$V_{OL ODR}$	ODR Output LOW Voltage ($I_{OL} = 8$ mA)		3.0V (any port)				0.2	V
V_{IH}	Input HIGH Voltage		3.0V (any port)		2.0		$V_{DDIO} + 0.2$	V
V_{IL}	Input LOW Voltage		3.0V (any port)		-0.2		0.7	V
I_{OZ}	Output Leakage Current		3.0V	3.0V	-1		1	μA
$I_{CEX ODR}$	ODR Output Leakage Current. $V_{OUT} = V_{CC}$		3.0V	3.0V	-1		1	μA
I_{IX}	Input Leakage Current		3.0V	3.0V	-1		1	μA
I_{CC}	Operating Current ($V_{CC} = \text{Max.}$, $I_{OUT} = 0$ mA) Outputs Disabled	Ind.	3.0V	3.0V		42	60	mA
I_{SB1}	Standby Current (Both Ports TTL Level) \overline{CE}_L and $\overline{CE}_R \geq V_{CC} - 0.2$, $SEM_L = SEM_R = V_{CC} - 0.2$, $f = f_{MAX}$	Ind.	3.0V	3.0V		7	10	μA
I_{SB2}	Standby Current (One Port TTL Level) \overline{CE}_L $\overline{CE}_R \geq V_{IH}$, $f = f_{MAX}$	Ind.	3.0V	3.0V		25	35	mA
I_{SB3}	Standby Current (Both Ports CMOS Level) \overline{CE}_L and $\overline{CE}_R \geq V_{CC} - 0.2V$, SEM_L and $SEM_R > V_{CC} - 0.2V$, $f = 0$	Ind.	3.0V	3.0V		6	8	μA
I_{SB4}	Standby Current (One Port CMOS Level) \overline{CE}_L $\overline{CE}_R \geq V_{IH}$, $f = f_{MAX}^{[21]}$	Ind.	3.0V	3.0V		25	35	mA

Capacitance^[22]

Parameter	Description	Test Conditions	Max	Unit
C_{IN}	Input Capacitance	$T_A = 25^\circ C$, $f = 1$ MHz, $V_{CC} = 3.0V$	9	pF
C_{OUT}	Output Capacitance		10	pF

Note

22. Tested initially and after any design or process changes that may affect these parameters.

AC Test Loads and Waveforms

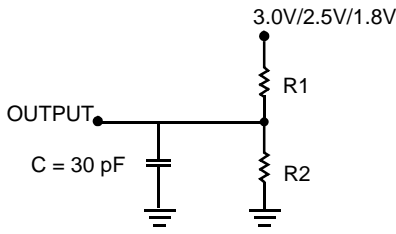

(a) Normal Load

	3.0V/2.5V	1.8V
R1	1022Ω	13500Ω
R2	792Ω	10800Ω

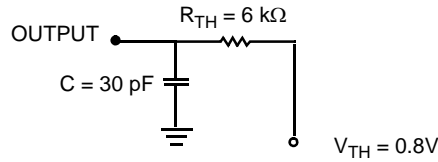

(b) Thévenin Equivalent (Load 1)

ALL INPUT PULSES

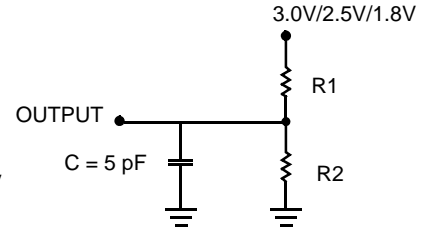
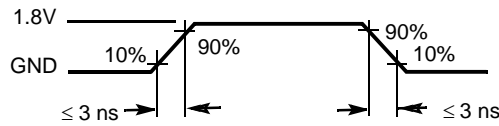

(c) Three-State Delay (Load 2)

(Used for t_{LZ} , t_{HZ} , t_{HZWE} , and t_{LZWE} including scope and jig)

Switching Characteristics for $V_{CC} = 1.8V$

Over the Operating Range^[23]

Parameter	Description	CYDM256B16, CYDM128B16, CYDM064B16		Unit
		-55		
		Min	Max	
Read Cycle				
t_{RC}	Read Cycle Time	55		ns
t_{AA}	Address to Data Valid		55	ns
t_{OHA}	Output Hold From Address Change	5		ns
$t_{ACE}^{[24]}$	\overline{CE} LOW to Data Valid		55	ns
t_{DOE}	\overline{OE} LOW to Data Valid		30	ns
$t_{LZOE}^{[25, 26, 27]}$	\overline{OE} Low to Low Z	5		ns
$t_{HZOE}^{[25, 26, 27]}$	\overline{OE} HIGH to High Z		25	ns
$t_{LZCE}^{[25, 26, 27]}$	\overline{CE} LOW to Low Z	5		ns
$t_{HZCE}^{[25, 26, 27]}$	\overline{CE} HIGH to High Z		25	ns
$t_{PU}^{[27]}$	\overline{CE} LOW to Power up	0		ns
$t_{PD}^{[27]}$	\overline{CE} HIGH to Power down		55	ns
$t_{ABE}^{[24]}$	Byte Enable Access Time		55	ns

Notes

- 23. Test conditions assume signal transition time of 3 ns or less, timing reference levels of $V_{CC}/2$, input pulse levels of 0 to V_{CC} , and output loading of the specified I_{OI}/I_{OH} and 30 pF load capacitance.
- 24. To access RAM, $\overline{CE} = L$, $\overline{UB} = L$, $\overline{SEM} = H$. To access semaphore, $\overline{CE} = H$ and $\overline{SEM} = L$. Either condition must be valid for the entire t_{SCE} time.
- 25. At any given temperature and voltage condition for any given device, t_{HZCE} is less than t_{LZCE} and t_{HZOE} is less than t_{LZOE} .
- 26. Test conditions used are Load 3.
- 27. This parameter is guaranteed but not tested. For information on port-to-port delay through RAM cells from writing port to reading port, refer to Read Timing with Busy waveform.

Switching Characteristics for V_{CC} = 1.8V (continued)

Over the Operating Range^[23]

Parameter	Description	CYDM256B16, CYDM128B16, CYDM064B16		Unit
		-55		
		Min	Max	
Write Cycle				
t _{WC}	Write Cycle Time	55		ns
t _{SCE} ^[24]	\overline{CE} LOW to Write End	45		ns
t _{AW}	Address Valid to Write End	45		ns
t _{HA}	Address Hold From Write End	0		ns
t _{SA} ^[24]	Address Setup to Write Start	0		ns
t _{PWE}	Write Pulse Width	40		ns
t _{SD}	Data Setup to Write End	30		ns
t _{HD}	Data Hold From Write End	0		ns
t _{HZWE} ^[26, 27]	R/W LOW to High Z		25	ns
t _{LZWE} ^[26, 27]	R/W HIGH to Low Z	0		ns
t _{WDD} ^[28]	Write Pulse to Data Delay		80	ns
t _{DDD} ^[28]	Write Data Valid to Read Data Valid		80	ns
Busy Timing ^[29]				
t _{BLA}	\overline{BUSY} LOW from Address Match		45	ns
t _{BHA}	\overline{BUSY} HIGH from Address Mismatch		45	ns
t _{BLC}	\overline{BUSY} LOW from \overline{CE} LOW		45	ns
t _{BHC}	\overline{BUSY} HIGH from \overline{CE} HIGH		45	ns
t _{PS} ^[30]	Port Setup for Priority	5		ns
t _{WB}	R/W HIGH after \overline{BUSY} (Slave)	0		ns
t _{WH}	R/W HIGH after \overline{BUSY} HIGH (Slave)	35		ns
t _{BDD} ^[31]	\overline{BUSY} HIGH to Data Valid		40	ns
Interrupt Timing ^[29]				
t _{INS}	\overline{INT} Set Time		45	ns
t _{INR}	\overline{INT} Reset Time		45	ns
Semaphore Timing				
t _{SOP}	SEM Flag Update Pulse (\overline{OE} or \overline{SEM})	15		ns
t _{SWRD}	SEM Flag Write to Read Time	10		ns
t _{SPS}	SEM Flag Contention Window	10		ns
t _{SAA}	SEM Address Access Time		55	ns

Notes

28. For information on port-to-port delay through RAM cells from writing port to reading port, refer to Read Timing with Busy waveform.

29. Test conditions used are Load 2.

30. Add 2ns to this parameter if V_{CC} and V_{DDIOR} are <1.8V, and V_{DDIOL} is >2.5V at temperature <0°C.

31. t_{BDD} is a calculated parameter and is the greater of t_{WDD} - t_{PWE} (actual) or t_{DDD} - t_{SD} (actual).

Switching Characteristics for $V_{CC} = 2.5V$

Over the Operating Range

Parameter	Description	CYDM256B16, CYDM128B16, CYDM064B16		Unit
		-55		
		Min	Max	
Read Cycle				
t_{RC}	Read Cycle Time	55		ns
t_{AA}	Address to Data Valid		55	ns
t_{OHA}	Output Hold From Address Change	5		ns
$t_{ACE}^{[24]}$	\overline{CE} LOW to Data Valid		55	ns
t_{DOE}	\overline{OE} LOW to Data Valid		30	ns
$t_{LZOE}^{[25, 26, 27]}$	\overline{OE} Low to Low Z	2		ns
$t_{HZOE}^{[25, 26, 27]}$	\overline{OE} HIGH to High Z		25	ns
$t_{LZCE}^{[25, 26, 27]}$	\overline{CE} LOW to Low Z	2		ns
$t_{HZCE}^{[25, 26, 27]}$	\overline{CE} HIGH to High Z		25	ns
$t_{PU}^{[27]}$	\overline{CE} LOW to Power up	0		ns
$t_{PD}^{[27]}$	\overline{CE} HIGH to Power down		55	ns
$t_{ABE}^{[24]}$	Byte Enable Access Time		55	ns
Write Cycle				
t_{WC}	Write Cycle Time	55		ns
$t_{SCE}^{[24]}$	\overline{CE} LOW to Write End	45		ns
t_{AW}	Address Valid to Write End	45		ns
t_{HA}	Address Hold From Write End	0		ns
$t_{SA}^{[24]}$	Address Setup to Write Start	0		ns
t_{PWE}	Write Pulse Width	40		ns
t_{SD}	Data Setup to Write End	30		ns
t_{HD}	Data Hold From Write End	0		ns
$t_{HZWE}^{[26, 27]}$	R/\overline{W} LOW to High Z		25	ns
$t_{LZWE}^{[26, 27]}$	R/\overline{W} HIGH to Low Z	0		ns
$t_{WDD}^{[28]}$	Write Pulse to Data Delay		80	ns
$t_{DDD}^{[28]}$	Write Data Valid to Read Data Valid		80	ns
Busy Timing^[29]				
t_{BLA}	\overline{BUSY} LOW from Address Match		45	ns
t_{BHA}	\overline{BUSY} HIGH from Address Mismatch		45	ns
t_{BLC}	\overline{BUSY} LOW from \overline{CE} LOW		45	ns
t_{BHC}	\overline{BUSY} HIGH from \overline{CE} HIGH		45	ns
$t_{PS}^{[30]}$	Port Setup for Priority	5		ns
t_{WB}	R/\overline{W} HIGH after \overline{BUSY} (Slave)	0		ns
t_{WH}	R/\overline{W} HIGH after \overline{BUSY} HIGH (Slave)	35		ns
$t_{BDD}^{[31]}$	\overline{BUSY} HIGH to Data Valid		40	ns

Switching Characteristics for $V_{CC} = 2.5V$ (continued)

Over the Operating Range

Parameter	Description	CYDM256B16, CYDM128B16, CYDM064B16		Unit
		-55		
		Min	Max	
Interrupt Timing ^[29]				
t_{INS}	\overline{INT} Set Time		45	ns
t_{INR}	\overline{INT} Reset Time		45	ns
Semaphore Timing				
t_{SOP}	SEM Flag Update Pulse (\overline{OE} or \overline{SEM})	15		ns
t_{SWRD}	SEM Flag Write to Read Time	10		ns
t_{SPS}	SEM Flag Contention Window	10		ns
t_{SAA}	SEM Address Access Time		55	ns

Switching Characteristics for $V_{CC} = 3.0V$

Over the Operating Range

Parameter	Description	CYDM256B16, CYDM128B16, CYDM064B16		Unit
		-55		
		Min	Max	
Read Cycle				
t_{RC}	Read Cycle Time	55		ns
t_{AA}	Address to Data Valid		55	ns
t_{OHA}	Output Hold From Address Change	5		ns
t_{ACE} ^[24]	\overline{CE} LOW to Data Valid		55	ns
t_{DOE}	\overline{OE} LOW to Data Valid		30	ns
t_{LZOE} ^[25, 26, 27]	\overline{OE} Low to Low Z	1		ns
t_{HZOE} ^[25, 26, 27]	\overline{OE} HIGH to High Z		25	ns
t_{LZCE} ^[25, 26, 27]	\overline{CE} LOW to Low Z	1		ns
t_{HZCE} ^[25, 26, 27]	\overline{CE} HIGH to High Z		25	ns
t_{PU} ^[27]	\overline{CE} LOW to Power up	0		ns
t_{PD} ^[27]	\overline{CE} HIGH to Power down		55	ns
t_{ABE} ^[24]	Byte Enable Access Time		55	ns
Write Cycle				
t_{WC}	Write Cycle Time	55		ns
t_{SCE} ^[24]	\overline{CE} LOW to Write End	45		ns
t_{AW}	Address Valid to Write End	45		ns
t_{HA}	Address Hold From Write End	0		ns
t_{SA} ^[24]	Address Setup to Write Start	0		ns
t_{PWE}	Write Pulse Width	40		ns
t_{SD}	Data Setup to Write End	30		ns
t_{HD}	Data Hold From Write End	0		ns

Switching Characteristics for $V_{CC} = 3.0V$ (continued)

Over the Operating Range

Parameter	Description	CYDM256B16, CYDM128B16, CYDM064B16		Unit
		-55		
		Min	Max	
$t_{HZWE}^{[26, 27]}$	R/W LOW to High Z		25	ns
$t_{LZWE}^{[26, 27]}$	R/W HIGH to Low Z	0		ns
$t_{WDD}^{[28]}$	Write Pulse to Data Delay		80	ns
$t_{DD}^{[28]}$	Write Data Valid to Read Data Valid		80	ns
Busy Timing^[29]				
t_{BLA}	\overline{BUSY} LOW from Address Match		45	ns
t_{BHA}	$BUSY$ HIGH from Address Mismatch		45	ns
t_{BLC}	\overline{BUSY} LOW from \overline{CE} LOW		45	ns
t_{BHC}	$BUSY$ HIGH from \overline{CE} HIGH		45	ns
$t_{PS}^{[30]}$	Port Setup for Priority	5		ns
t_{WB}	R/W HIGH after \overline{BUSY} (Slave)	0		ns
t_{WH}	R/W HIGH after $BUSY$ HIGH (Slave)	35		ns
$t_{BDD}^{[31]}$	\overline{BUSY} HIGH to Data Valid		40	ns
Interrupt Timing^[29]				
t_{INS}	\overline{INT} Set Time		45	ns
t_{INR}	\overline{INT} Reset Time		45	ns
Semaphore Timing				
t_{SOP}	SEM Flag Update Pulse (\overline{OE} or \overline{SEM})	15		ns
t_{SWRD}	SEM Flag Write to Read Time	10		ns
t_{SPS}	SEM Flag Contention Window	10		ns
t_{SAA}	SEM Address Access Time		55	ns

Switching Waveforms

Figure 2. Read Cycle No.1 (Either Port Address Access) [32, 33, 34]

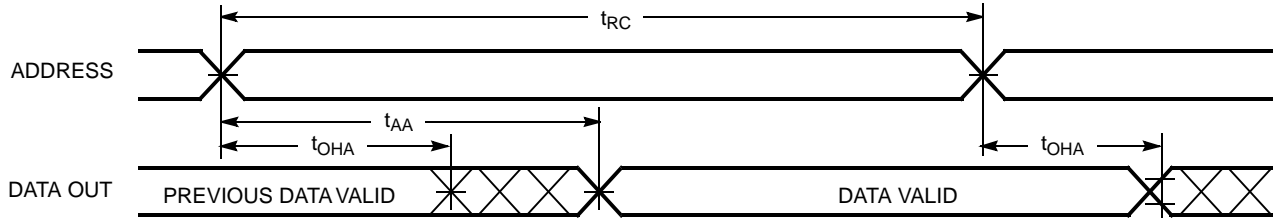

Figure 3. Read Cycle No.2 (Either Port $\overline{CE}/\overline{OE}$ Access) [32, 35, 36]

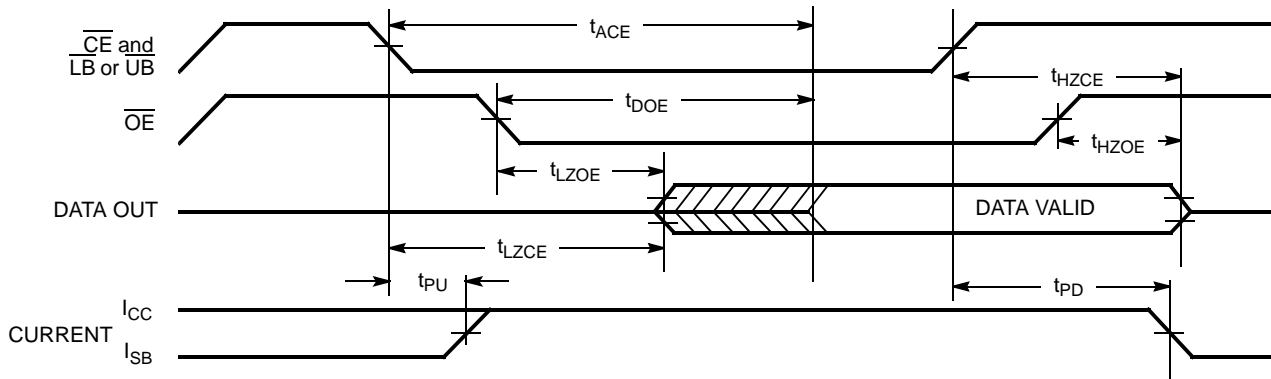
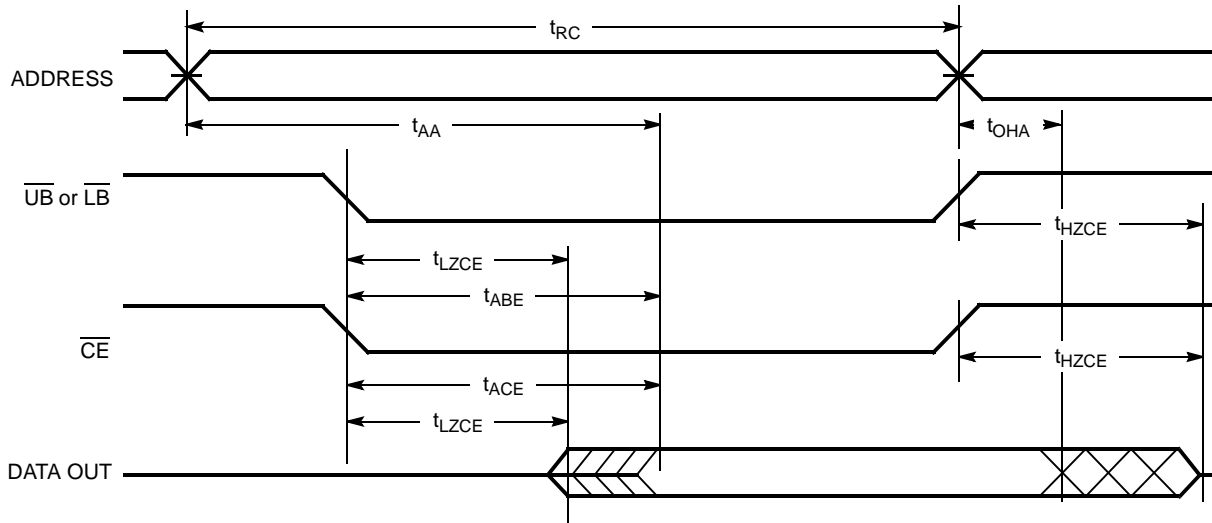

Figure 4. Read Cycle No. 3 (Either Port) [32, 34, 37, 38]



Notes

- 32. R/\overline{W} is HIGH for read cycles.
- 33. Device is continuously selected $\overline{CE} = V_{IL}$ and \overline{UB} or $\overline{LB} = V_{IL}$. This waveform cannot be used for semaphore reads.
- 34. $\overline{OE} = V_{IL}$.
- 35. Address valid before or coincident with \overline{CE} transition LOW.
- 36. To access RAM, $\overline{CE} = V_{IL}$, \overline{UB} or $\overline{LB} = V_{IL}$, $\overline{SEM} = V_{IH}$. To access semaphore, $\overline{CE} = V_{IH}$, $\overline{SEM} = V_{IL}$.
- 37. R/\overline{W} must be HIGH during all address transitions.
- 38. A write occurs during the overlap (t_{SCE} or t_{PWE}) of a LOW \overline{CE} or \overline{SEM} and a LOW \overline{UB} or \overline{LB} .

Switching Waveforms (continued)

Figure 5. Write Cycle No.1: R/W Controlled Timing [37, 38, 39, 40, 41, 42]

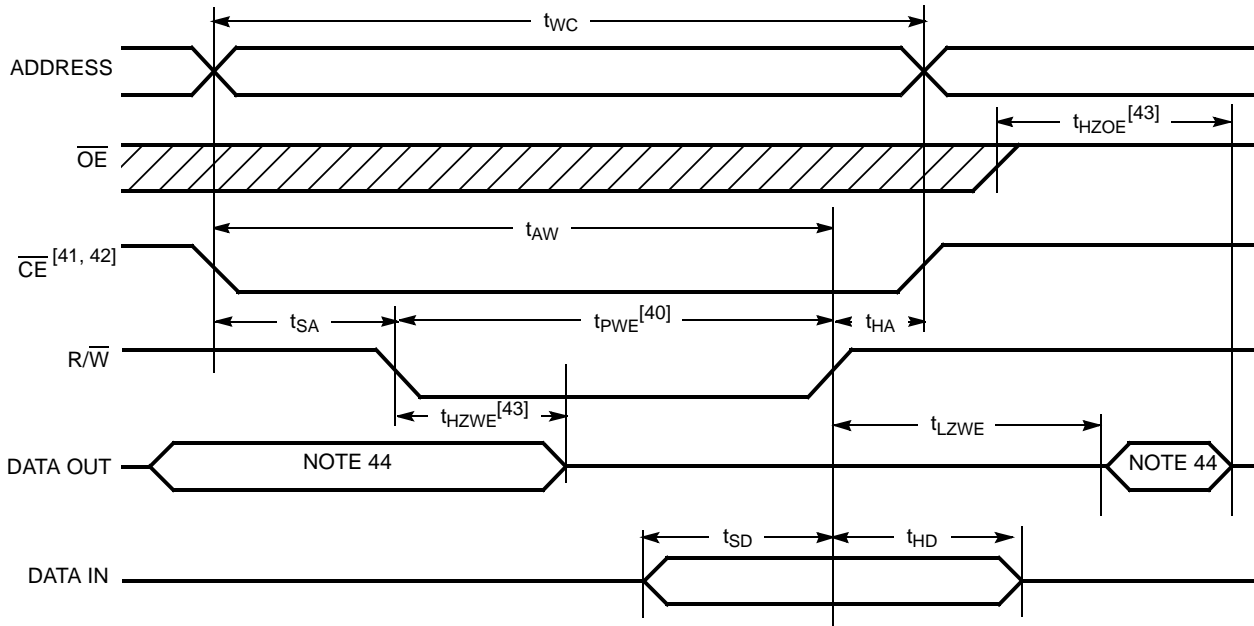
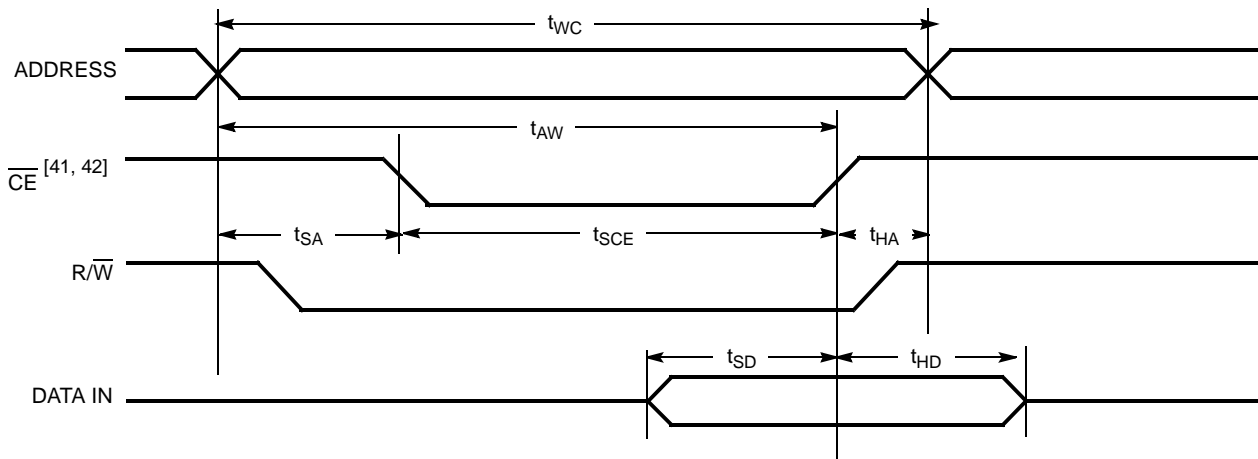

Figure 6. Write Cycle No. 2: CE Controlled Timing [37, 38, 39, 44]



Notes

- 39. t_{HA} is measured from the earlier of \overline{CE} or $\overline{R/W}$ or (\overline{SEM} or $\overline{R/W}$) going HIGH at the end of write cycle.
- 40. If \overline{OE} is LOW during a $\overline{R/W}$ controlled write cycle, the write pulse width must be the larger of t_{PWE} or $(t_{HZWE} + t_{SD})$ to allow the IO drivers to turn off and data to be placed on the bus for the required t_{SD} . If \overline{OE} is HIGH during an $\overline{R/W}$ controlled write cycle, this requirement does not apply and the write pulse can be as short as the specified t_{PWE} .
- 41. To access RAM, $\overline{CE} = V_{IL}$, $\overline{SEM} = V_{IH}$.
- 42. To access upper byte, $\overline{CE} = V_{IL}$, $\overline{UB} = V_{IL}$, $\overline{SEM} = V_{IH}$.
To access lower byte, $\overline{CE} = V_{IL}$, $\overline{LB} = V_{IL}$, $\overline{SEM} = V_{IH}$.
- 43. Transition is measured ± 0 mV from steady state with a 5 pF load (including scope and jig). This parameter is sampled and not 100% tested.
- 44. During this period, the IO pins are in the output state, and input signals must not be applied.

Switching Waveforms (continued)

Figure 7. Semaphore Read After Write Timing (Either Side) [45, 46]

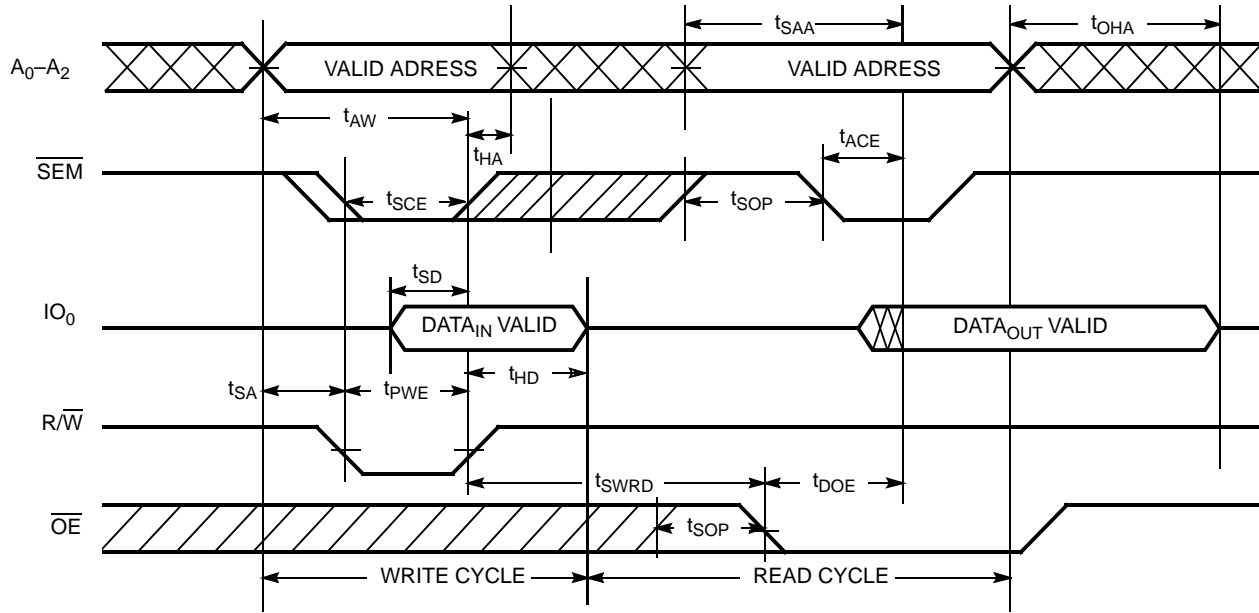
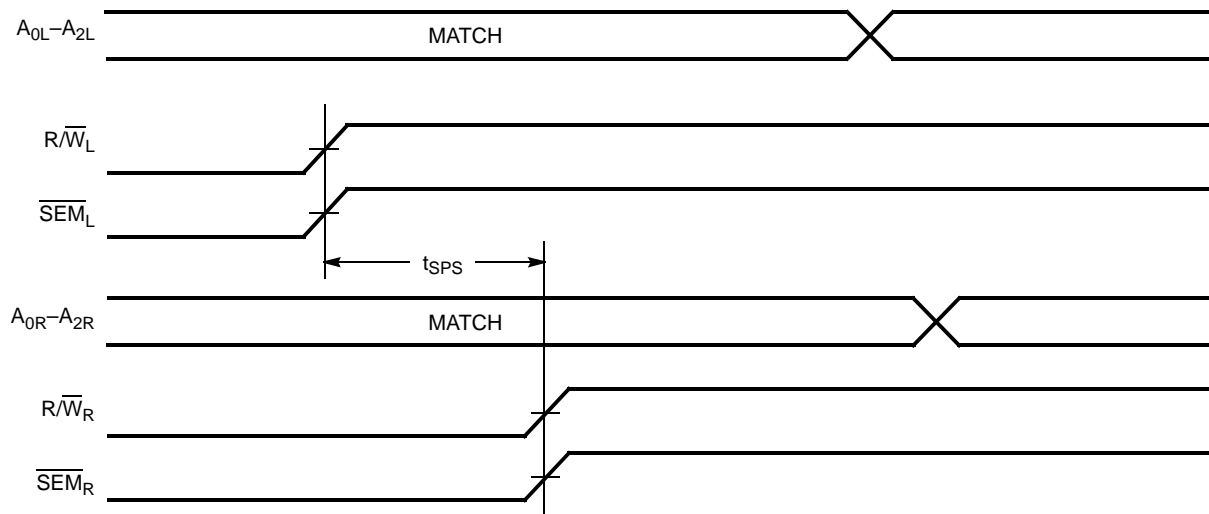

Figure 8. Timing Diagram of Semaphore Contention [47, 48]



Notes

- 45. If the \overline{CE} or \overline{SEM} LOW transition occurs simultaneously with or after the R/\overline{W} LOW transition, the outputs remain in the high impedance state.
- 46. \overline{CE} = HIGH for the duration of the above timing (both write and read cycle).
- 47. IO_{0R} = IO_{0L} = LOW (request semaphore); CE_R = CE_L = HIGH.
- 48. If t_{SPS} is violated, the semaphore is definitely obtained by one side or the other, but the side that gets the semaphore cannot be predicted.

Switching Waveforms (continued)

Figure 9. Timing Diagram of Read with $\overline{\text{BUSY}}$ ($\text{M}/\overline{\text{S}} = \text{HIGH}$) [49]

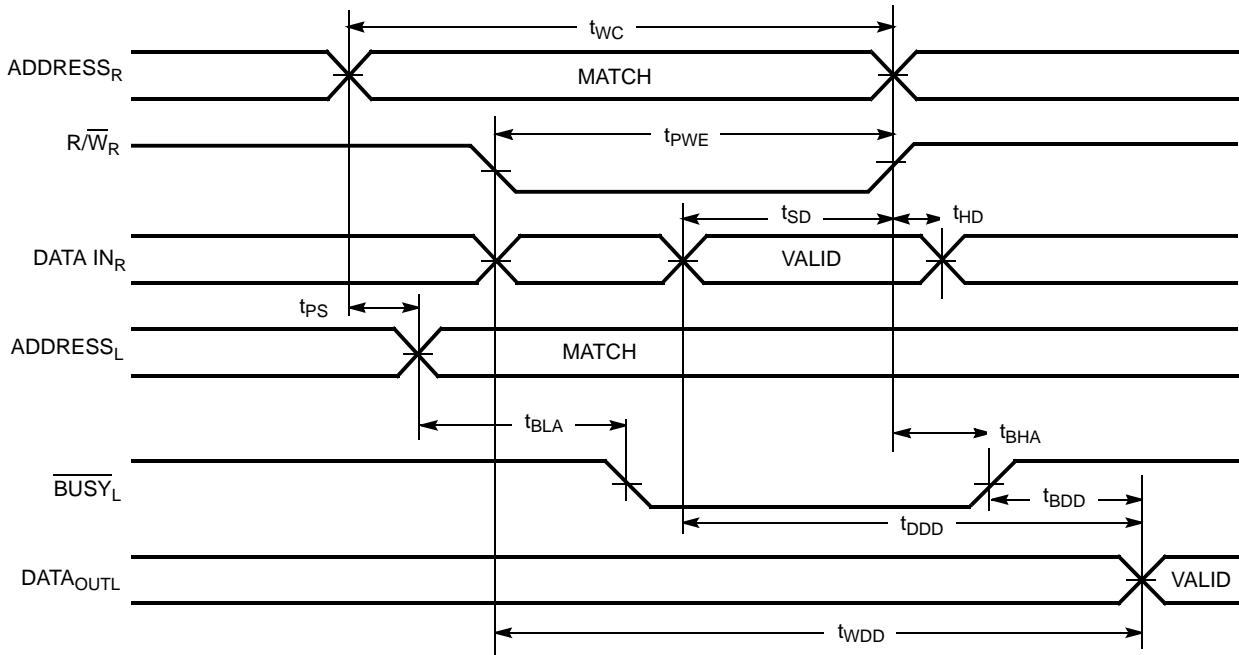
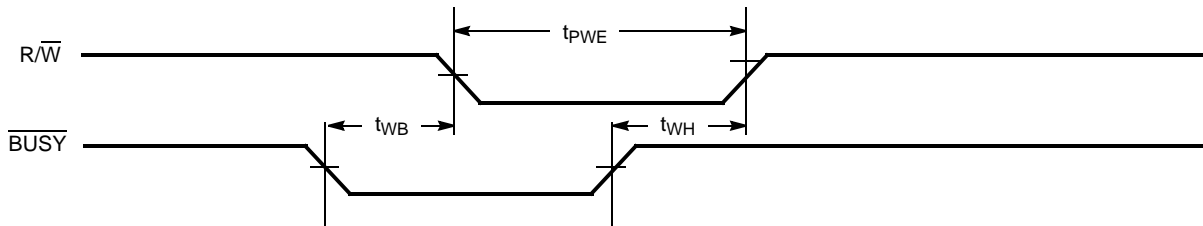

Figure 10. Write Timing with Busy Input ($\text{M}/\overline{\text{S}} = \text{LOW}$)



Note
49. $\overline{\text{CE}}_L = \overline{\text{CE}}_R = \text{LOW}$.

Switching Waveforms (continued)

Figure 11. Busy Timing Diagram No.1 (\overline{CE} Arbitration)

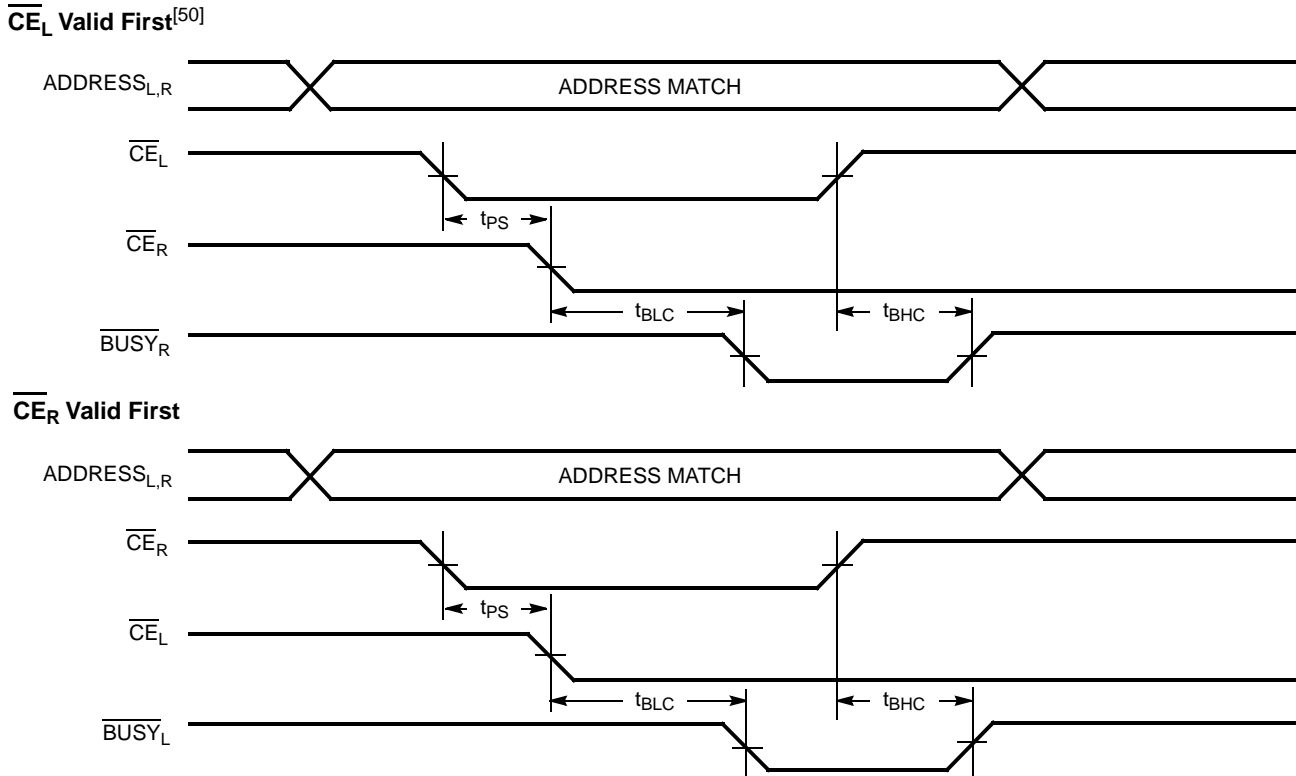
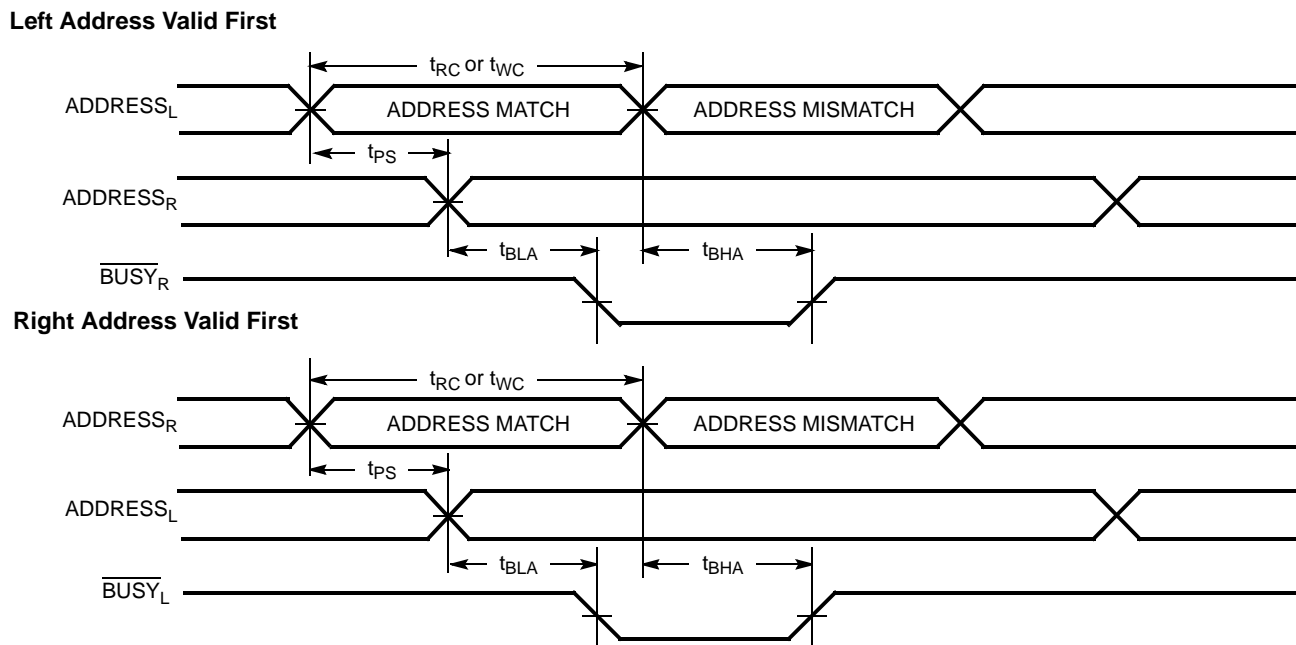

Figure 12. Busy Timing Diagram No.2 (Address Arbitration) [50]



Note

50. If t_{PS} is violated, the busy signal is asserted on one side or the other, but there is no guarantee to which side \overline{BUSY} is asserted.

Switching Waveforms (continued)

Figure 13. Interrupt Timing Diagrams

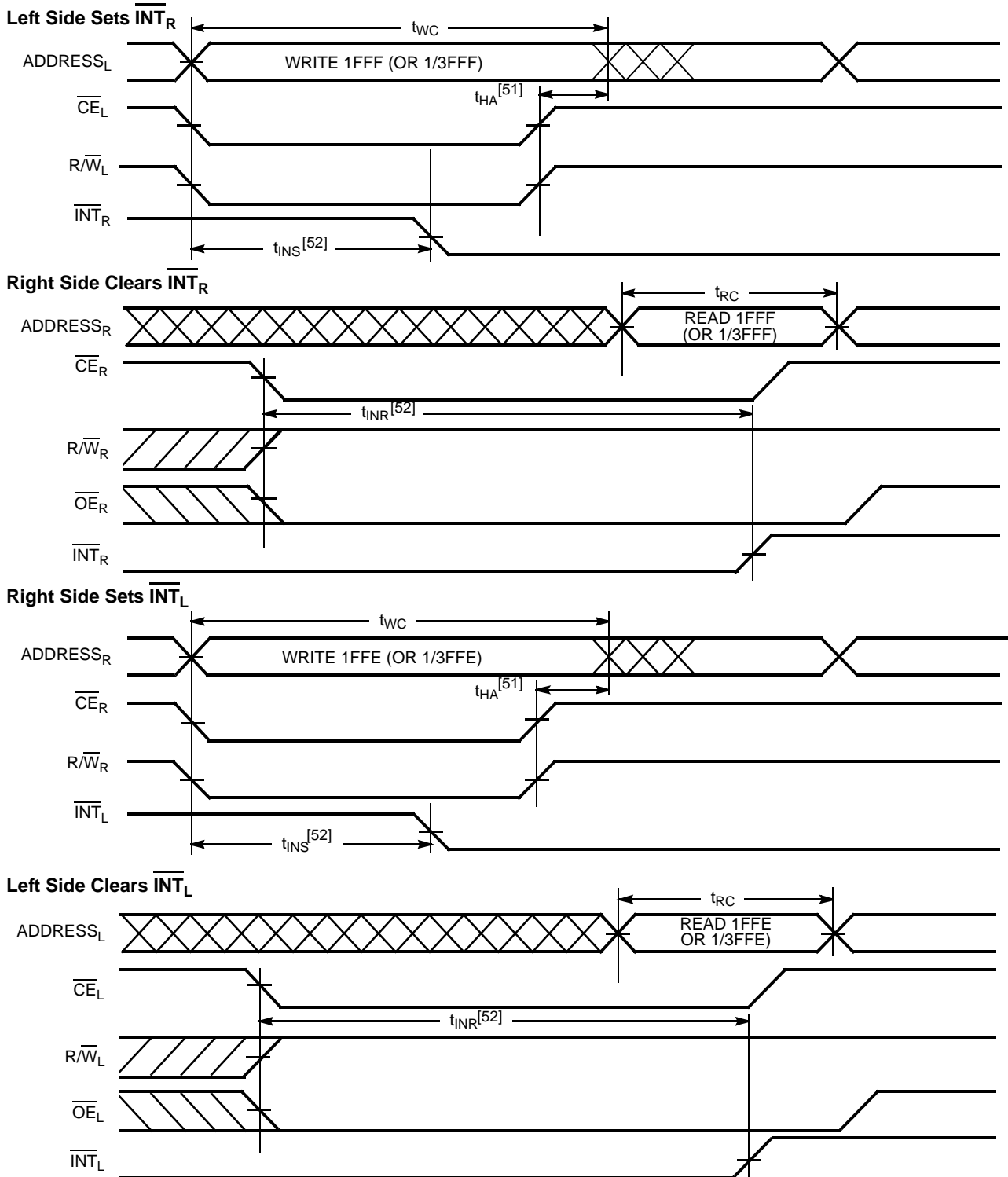

Notes

- 51. t_{HA} depends on which enable pin (\overline{CE}_L or $\overline{R/W}_L$) is deasserted first.
- 52. t_{INS} or t_{INR} depends on which enable pin (\overline{CE}_L or $\overline{R/W}_L$) is asserted last.

Ordering Information

Table 7. 16K x16 1.8V Asynchronous Dual-Port SRAM

Speed (ns)	Ordering Code	Package Name	Package Type	Operating Range
55	CYDM256B16-55BVXC	BZ100	100-ball Pb-free 0.5 mm Pitch BGA	Commercial
55	CYDM256B16-55BVXI	BZ100	100-ball Pb-free 0.5 mm Pitch BGA	Industrial

Table 8. 8K x16 1.8V Asynchronous Dual-Port SRAM

Speed (ns)	Ordering Code	Package Name	Package Type	Operating Range
55	CYDM128B16-55BVXC	BZ100	100-ball Pb-free 0.5 mm Pitch BGA	Commercial
55	CYDM128B16-55BVXI	BZ100	100-ball Pb-free 0.5 mm Pitch BGA	Industrial

Table 9. 4K x16 1.8V Asynchronous Dual-Port SRAM

Speed (ns)	Ordering Code	Package Name	Package Type	Operating Range
55	CYDM064B16-55BVXC	BZ100	100-ball Pb-free 0.5 mm Pitch BGA	Commercial
55	CYDM064B16-55BVXI	BZ100	100-ball Pb-free 0.5 mm Pitch BGA	Industrial

Package Diagram

Figure 14. 100 VFBGA (6 x 6 x 1.0 mm) BZ100A

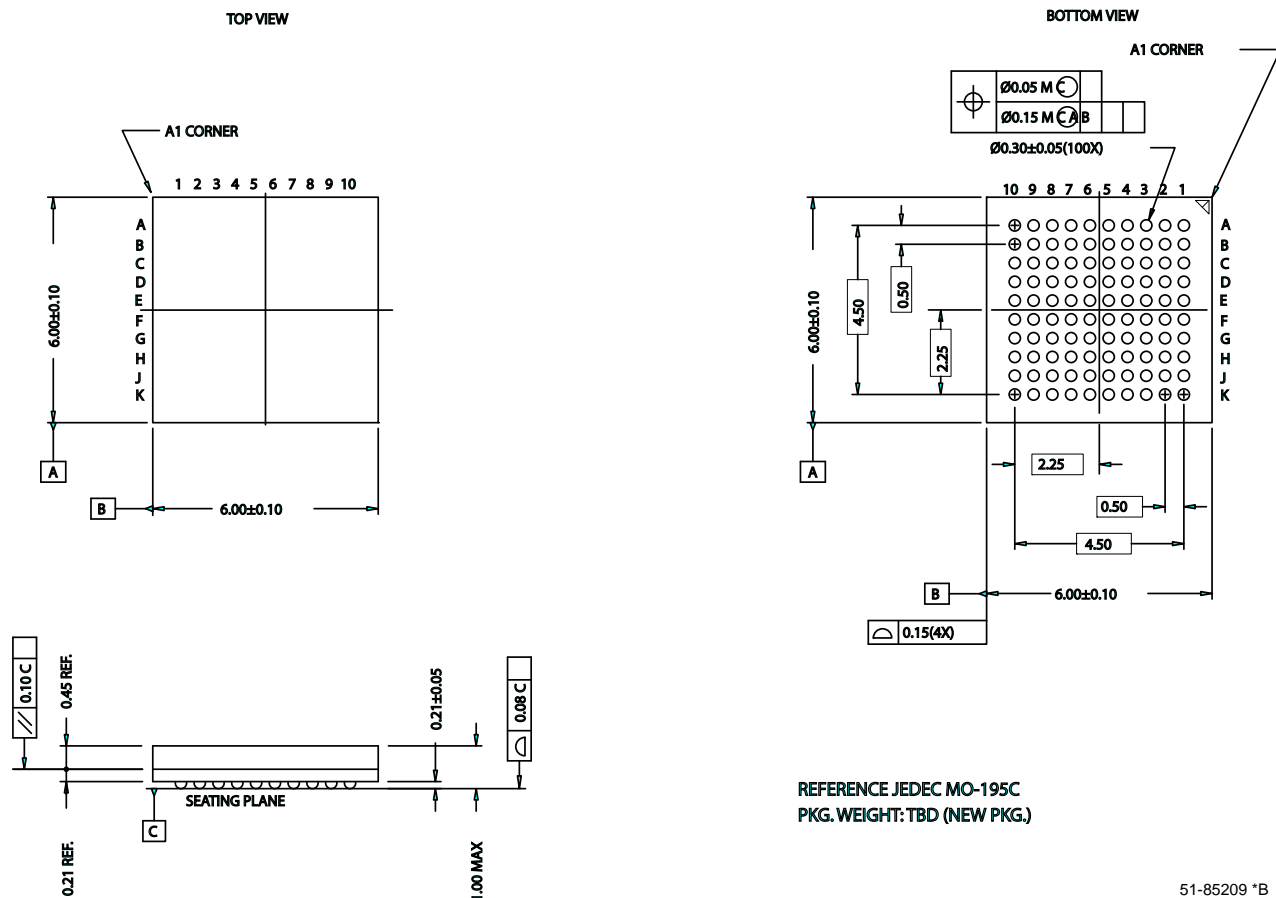

Document History Page

Document Title: CYDM064B16, CYDM128B16, CYDM256B16 1.8V 4K/8K/16K x 16 and 8K/16K x 8 MoBL [®] Dual-Port Static RAM				
Document Number: 001-00217				
REV.	ECN NO.	Orig. of Change	Submission Date	Description of Change
**	369423	YDT		New data sheet
*A	381721	YDT		Updated 2.5V/3.0V ICC, ISB1, ISB2, ISB4 Updated VOL ODR to 0.2V
*B	396697	KGH		Updated ISB2 and ISB4 typo to mA. Updated tINS and tINR for -55 to 31ns.
*C	404777	KGH		Updated I _{OH} and I _{OL} values for the 1.8V, 2.5V and 3.0V parameters V _{OH} and V _{OL} Replaced -35 speed bin with -40 Updated Switching Characteristics for V _{CC} = 2.5V and V _{CC} = 3.0V Included note 35
*D	426637	KGH		Removed part numbers CYDM128B08 and CYDM064B08
*E	733676	HKH		Corrected typo for power supply description in page 4 (3.0V instead of 3.3V) Updated tDDD timing value to be consistent with tWDD
*F	2545957	OGC/AESA	07/31/2008	Removed all details of -40ns parts. Updated data sheet template.

Sales, Solutions, and Legal Information

Worldwide Sales and Design Support

Cypress maintains a worldwide network of offices, solution centers, manufacturer's representatives, and distributors. To find the office closest to you, visit us at cypress.com/sales.

Products

PSoC	psoc.cypress.com
Clocks & Buffers	clocks.cypress.com
Wireless	wireless.cypress.com
Memories	memory.cypress.com
Image Sensors	image.cypress.com

PSoC Solutions

General	psoc.cypress.com/solutions
Low Power/Low Voltage	psoc.cypress.com/low-power
Precision Analog	psoc.cypress.com/precision-analog
LCD Drive	psoc.cypress.com/lcd-drive
CAN 2.0b	psoc.cypress.com/can
USB	psoc.cypress.com/usb

© Cypress Semiconductor Corporation, 2005-2008. The information contained herein is subject to change without notice. Cypress Semiconductor Corporation assumes no responsibility for the use of any circuitry other than circuitry embodied in a Cypress product. Nor does it convey or imply any license under patent or other rights. Cypress products are not warranted nor intended to be used for medical, life support, life saving, critical control or safety applications, unless pursuant to an express written agreement with Cypress. Furthermore, Cypress does not authorize its products for use as critical components in life-support systems where a malfunction or failure may reasonably be expected to result in significant injury to the user. The inclusion of Cypress products in life-support systems application implies that the manufacturer assumes all risk of such use and in doing so indemnifies Cypress against all charges.

Any Source Code (software and/or firmware) is owned by Cypress Semiconductor Corporation (Cypress) and is protected by and subject to worldwide patent protection (United States and foreign), United States copyright laws and international treaty provisions. Cypress hereby grants to licensee a personal, non-exclusive, non-transferable license to copy, use, modify, create derivative works of, and compile the Cypress Source Code and derivative works for the sole purpose of creating custom software and/or firmware in support of licensee product to be used only in conjunction with a Cypress integrated circuit as specified in the applicable agreement. Any reproduction, modification, translation, compilation, or representation of this Source Code except as specified above is prohibited without the express written permission of Cypress.

Disclaimer: CYPRESS MAKES NO WARRANTY OF ANY KIND, EXPRESS OR IMPLIED, WITH REGARD TO THIS MATERIAL, INCLUDING, BUT NOT LIMITED TO, THE IMPLIED WARRANTIES OF MERCHANTABILITY AND FITNESS FOR A PARTICULAR PURPOSE. Cypress reserves the right to make changes without further notice to the materials described herein. Cypress does not assume any liability arising out of the application or use of any product or circuit described herein. Cypress does not authorize its products for use as critical components in life-support systems where a malfunction or failure may reasonably be expected to result in significant injury to the user. The inclusion of Cypress' product in a life-support systems application implies that the manufacturer assumes all risk of such use and in doing so indemnifies Cypress against all charges.

Use may be limited by and subject to the applicable Cypress software license agreement.